



THE
HYPERION
MULTI-SLIDE
DOOR

SITE INSTALLATION GUIDE

2026

ENNION
DOORS

SITE FABRICATION

START HERE

1 Connect the jambs an bottom track.



2 Apply suitable sealant to profile ends. It is important to seal the bottom profile at both ends to prevent water from draining into the cleats.

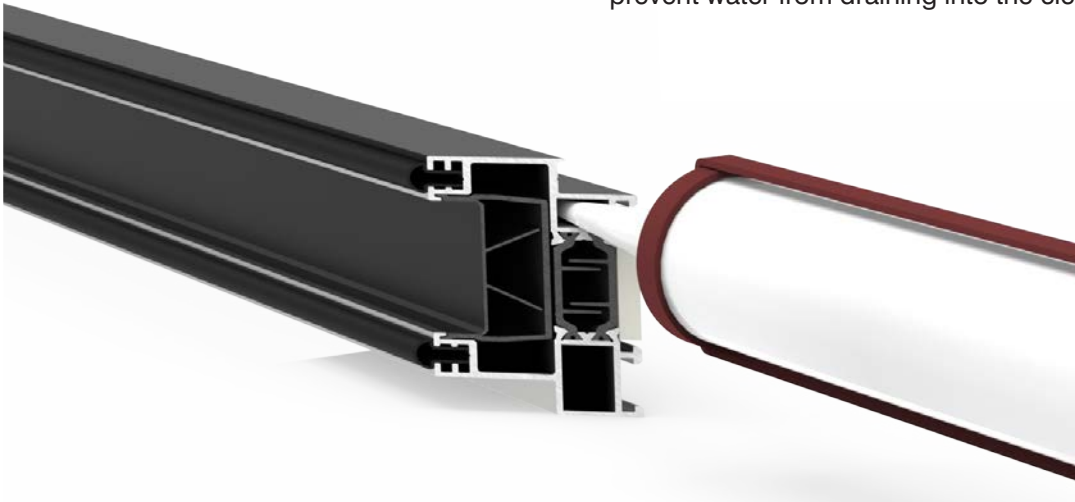

3 Insert cleats to the frame.

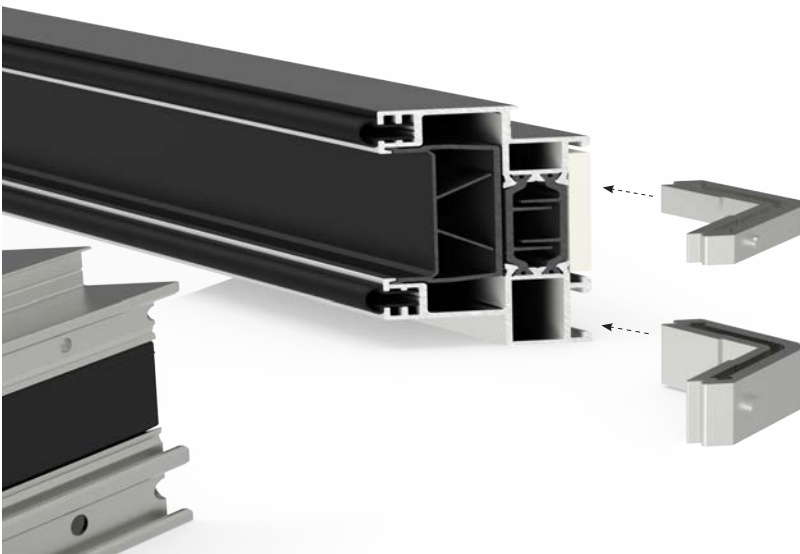

4 Join the jamb to the bottom track.

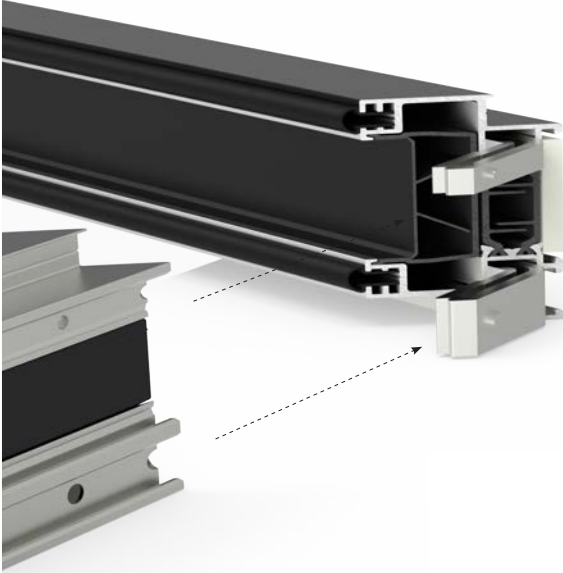

5 Tighten the cleat.



6 Check the joint, remove excess sealant and repeat the process for the second profile.

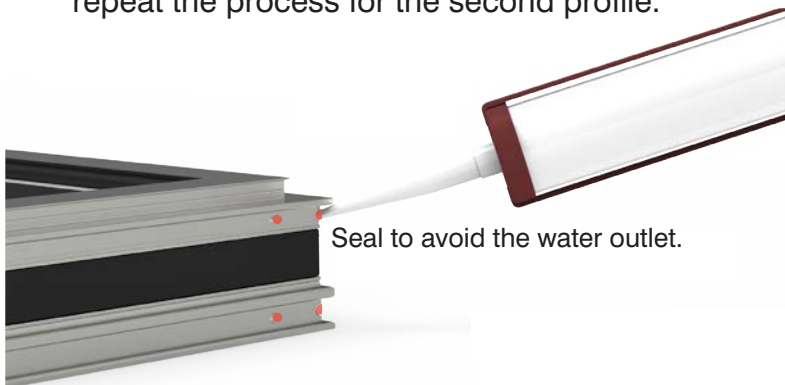

7 Assemble all frame profiles.



8 Glazing wedges are required.

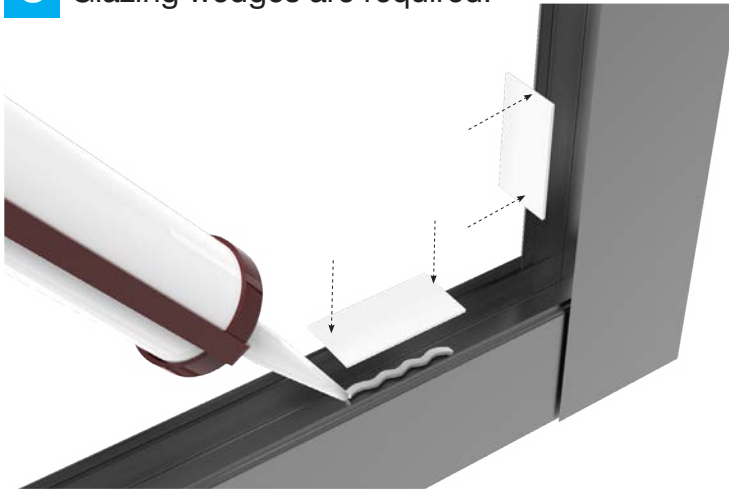

IT IS RECOMMENDED TO POSITION THE GLAZING WEDGES ACCORDING TO THESE CONFIGURATIONS:

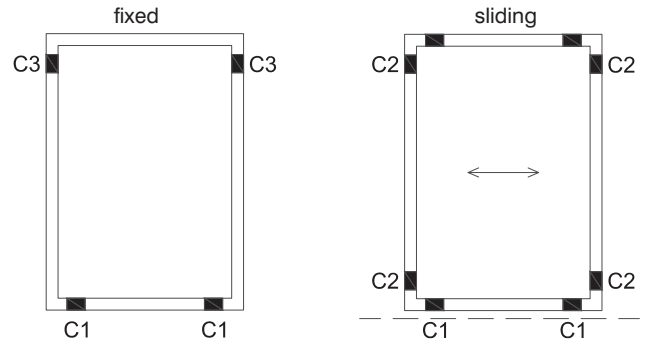

C1 = Support glazing wedges
C2 = Perimeter glazing wedges
C3 = Security glazing wedges

Glazing wedges must be placed towards the inside of the bearing points.

NOTE: The glazing wedges must be fitted as shown in the sketch shown above, without adding other glazing wedges in different positions.

The distance between the axis of the glazing wedges and the edge the glass will be approximately $L/10$ (L = length of the glass).

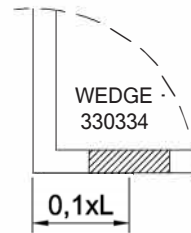

9 Insert the glass into the sash.

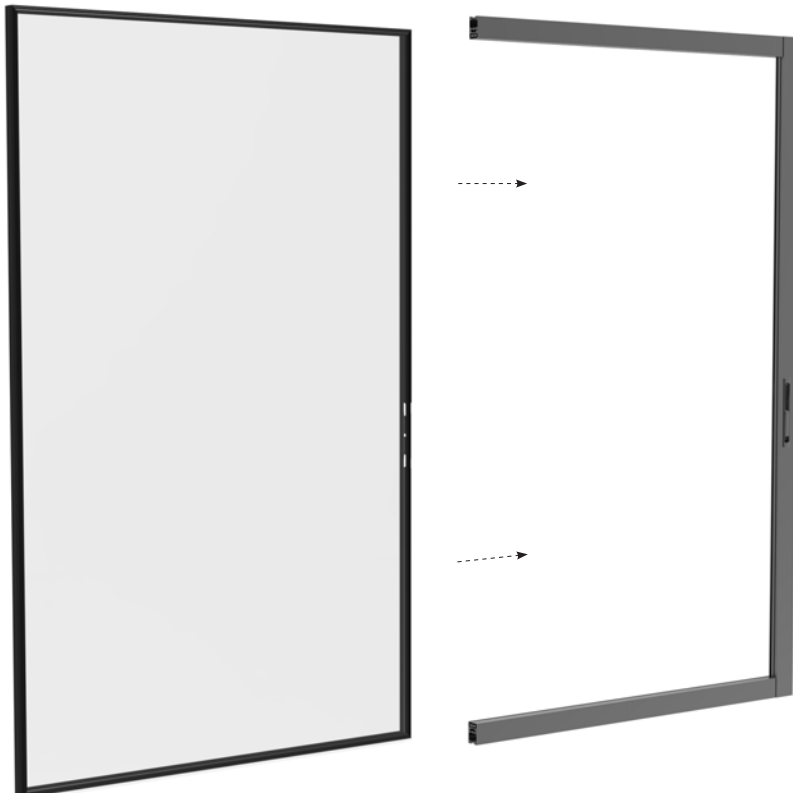

10 Apply sealant on interlock side.



NOTE: Structural sealing of the glass is recommended.

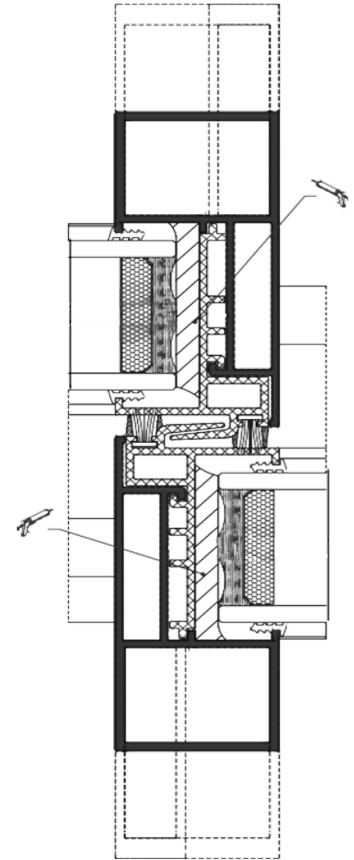
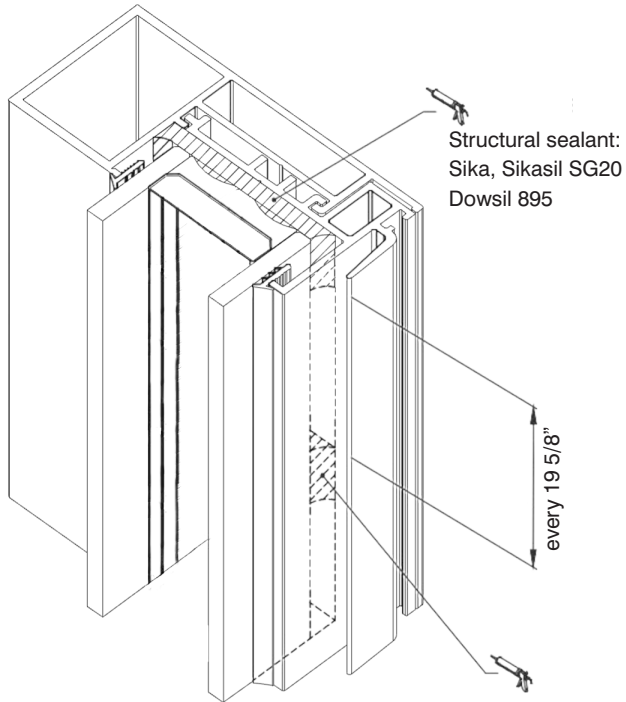

11 Assemble the interlock side.



12 Place the bearings.



IT IS RECOMMENDED TO POSITION THE BEARINGS ACCORDING TO THESE CONFIGURATIONS:

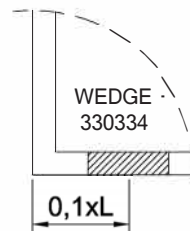
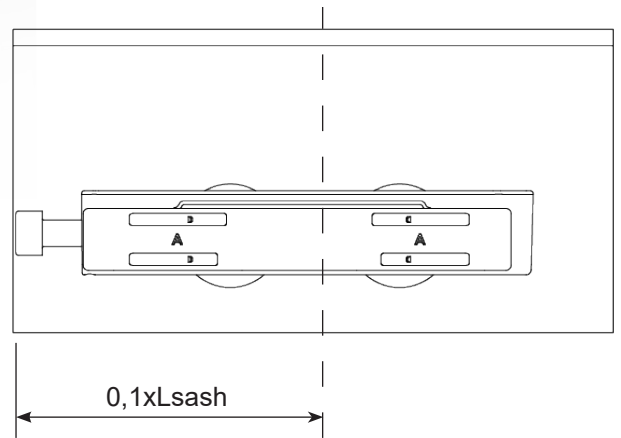
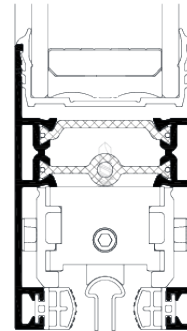

NOTE: The distance between the bearings axis and the edge of the glass will be approximately $L/10$ (L = length of the glass).

**SITE
INSTALLATION**

CONTINUE

13 & **14** Level the threshold in both directions.

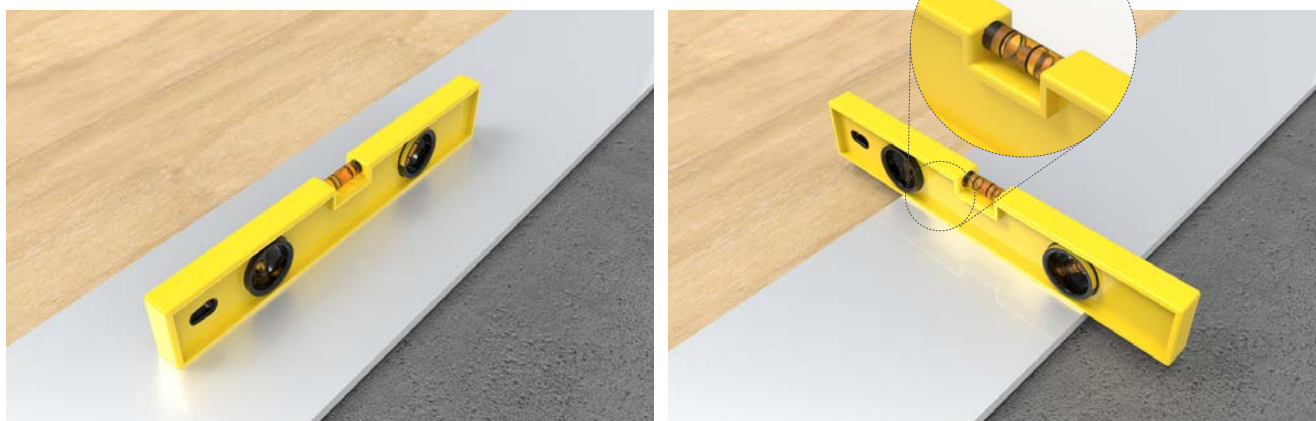

NOTE: The surface resistance must properly support the window weight.

15 Measure **widths** and **heights** in several points.

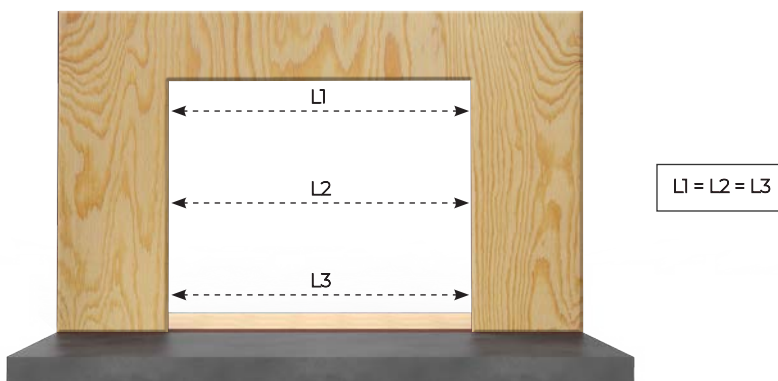
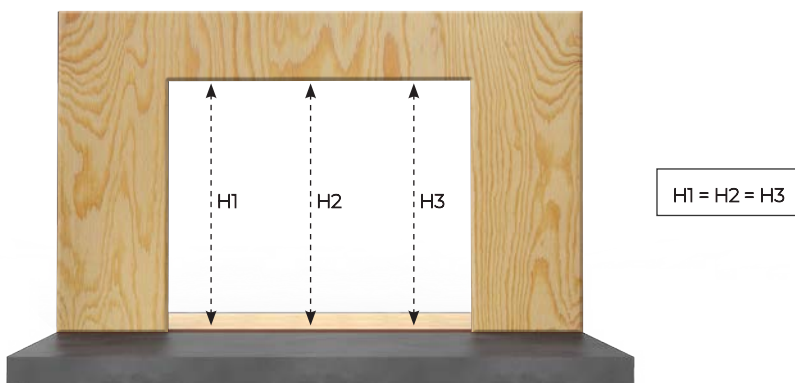

While fixing the frame to the structure, the separation between screws is recommended to not exceed 24 inches. The depth of the fastening on site should never be less than 1 1/8 inches (See recommendations for use).

SITE INSTALLATION CHART

minimum screw depth inches	7/8	1 1/8	1 5/8	2	2 3/8
HOLLOW BRICK (2 walls)					
WOOD AND LIGHTWEIGHT CONCRETE					
STONE					
SOLID BRICK					
SOLID WALL					
CONCRETE					

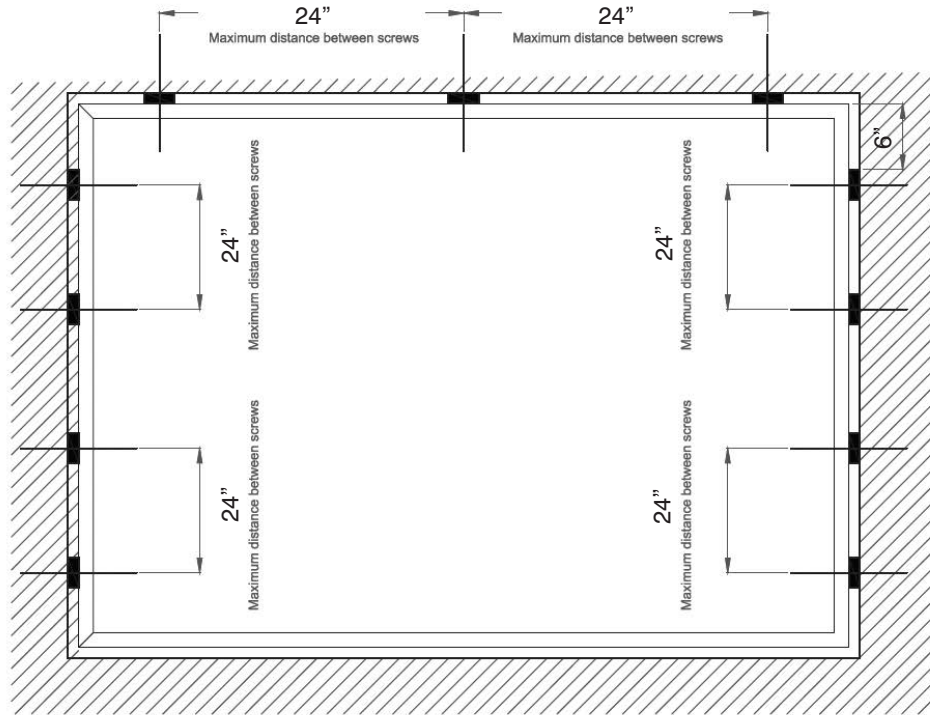

16 Lift frame into the opening, ensuring drainage caps are situated externally.

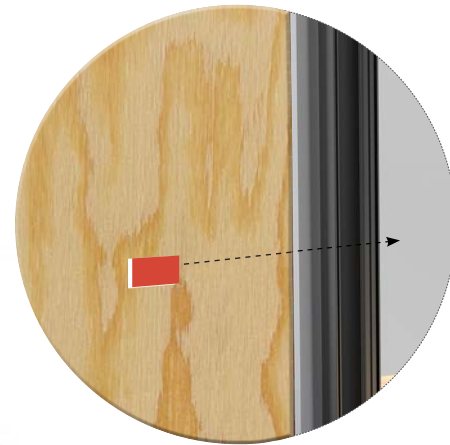

NOTE: In case it is incorrectly leveled, insert wedges above both jambs for an appropriate leveling and plumbing.

17 Accurately measure the internal frame dimensions.

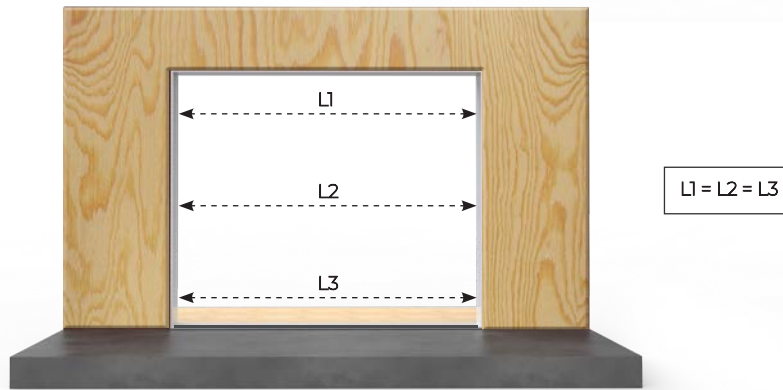
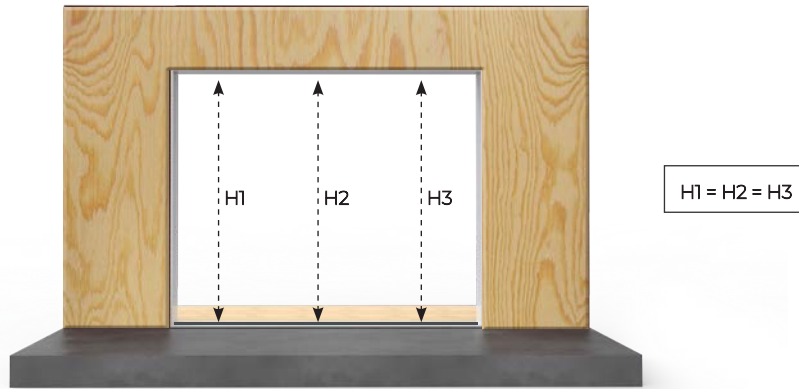

18 Measure diagonally from corner to corner to check the frame is square.

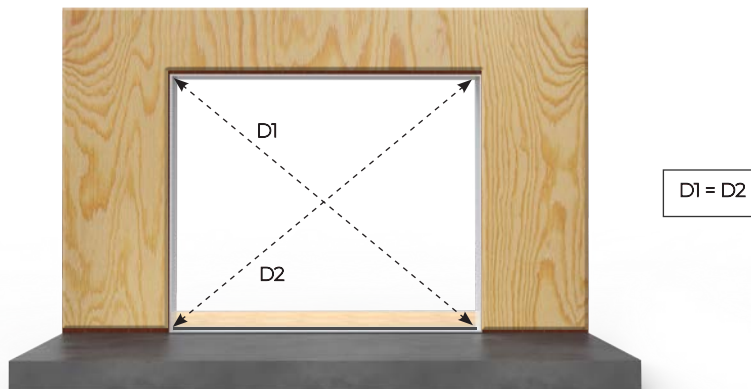

19 Use shims in order to ensure the jambs are correctly leveled.

NOTE: Place shims also along the frame for consistent internal frame sizes. Ensure the frame does not bow in any direction.

Ensure that the building does not transmit any load to the frame.

The bottom frame must be secured and not move.



20 Level out jambs in both directions.



- 21** If possible, fixing points should be on both sides of the frame, in a zigzag pattern.

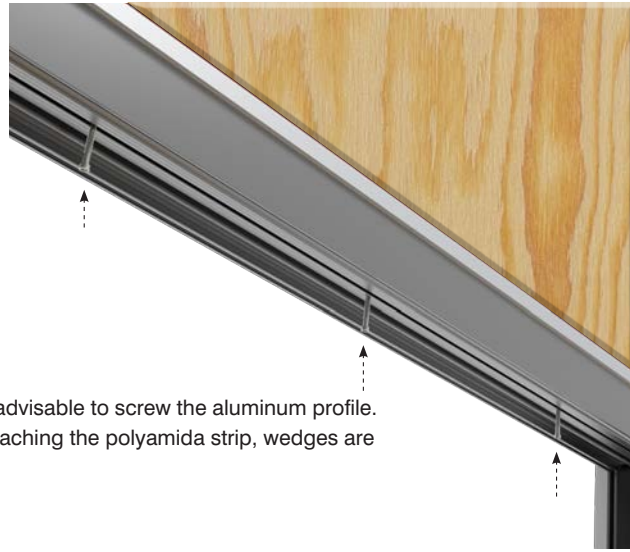
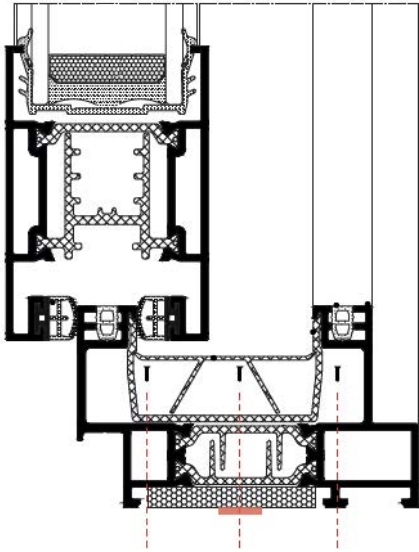

NOTE: It is advisable to screw the aluminum profile. In case of reaching the polyamida strip, wedges are needed.

- 22** Drill and countersink an appropriate sized fixing hole through the frame. This should be no more than 7 3/4 inches from the external corner of the frame.



- 23** Place a suitable sealant in the fixing hole.

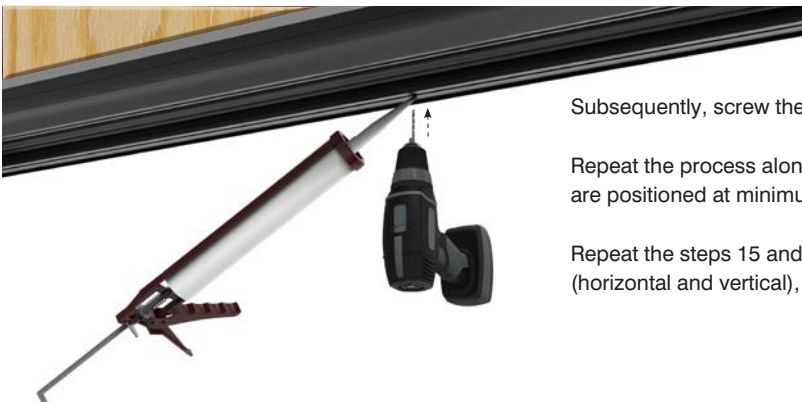

Subsequently, screw the fixing in place.

Repeat the process along the bottom track, ensuring screws are positioned at minimum of 36 inches intervals.

Repeat the steps 15 and 16 on the four profiles of the frame (horizontal and vertical), so as to properly fix it to the wall.

24 Insert top of sash into top rail channel.

25 Swing bottom of sash above running gear.



26 Insert top of sash into top rail channel.

27 Swing bottom of sash above running gear.



28 Adjust the bearings with an allen key after the sash has been installed.

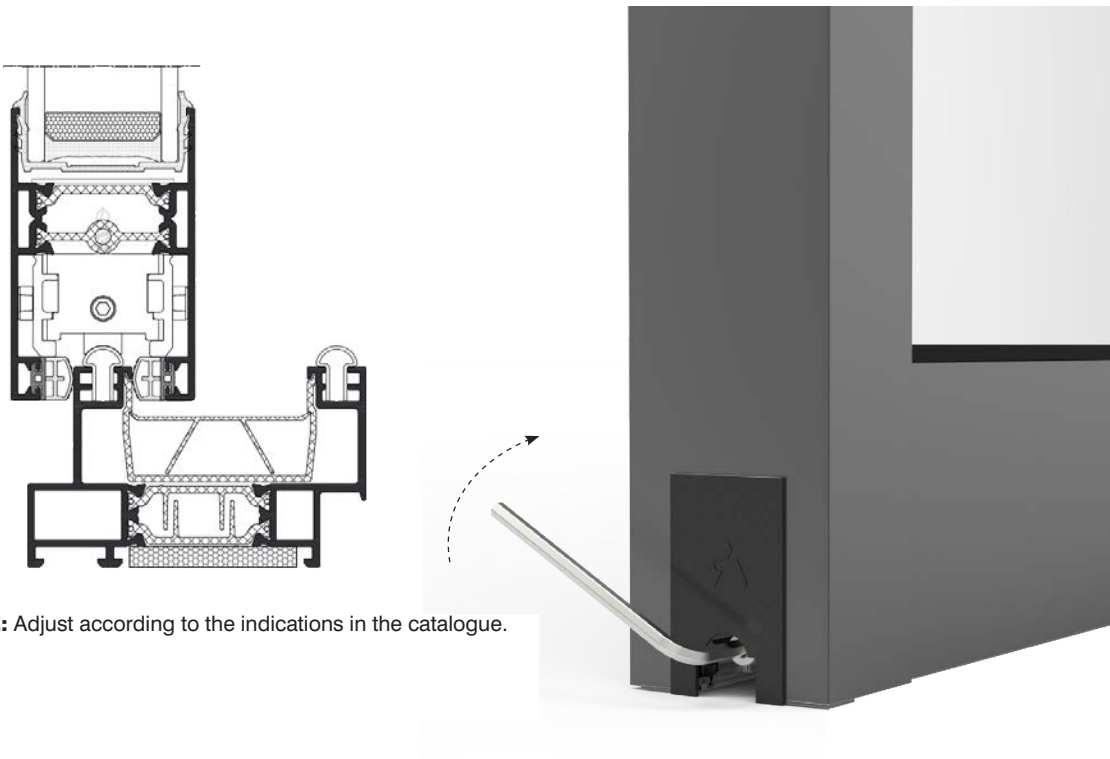

NOTE: Adjust according to the indications in the catalogue.

29 Installation completed.



ENNION DOORS

SO CA	1455 Columbia Ave Riverside CA 92507	909-946-3697
NO CA	5253 Business Center Dr Fairfield CA 94534	909-946-3697
NV	1950 East Maule Ave Las Vegas NV 89119	702-946-3697
AZ	2417 South 50th Ave Phoenix AZ 85043	909-946-3697

www.ennion.com sales@ennion.com